

Model RGAC/SGAC Self Contained Cooling/Gas Heat Units

Supersedes: 145.24-O1 (708)

Form 145.24-O1 (908)

MODELS RGAC & SGAC - R22 USER'S INFORMATION, MAINTENANCE AND SERVICE MANUAL

CATEGORY III GAS HEATING/ELECTRIC COOLING UNITS

Model RGAC Capacities*
18,000, 24,000 Btu/Hr - Cooling
40,000, 60,000 Btu/Hr. Heating

Model SGAC Capacities*
12,000, 18,000, 24,000 & 30,000 Btu/Hr - Cooling
20,000, 40,000, 60,000 & 80,000 Btu/Hr. - Heating

* Not all cooling capacities available in all heating capacities.



FIRE OR EXPLOSION HAZARD

Failure to follow safety warnings exactly could result in serious injury, death or property damage.

- **Do not store or use gasoline or other flammable vapors and liquids in the vicinity of this or any other appliance.**
- **WHAT TO DO IF YOU SMELL GAS**
 - **Do not try to light any appliance.**
 - **Do not touch any electrical switch; do not use any phone in your building.**
 - **Immediately call your gas supplier from a neighbor's phone. Follow the gas supplier's instructions.**
 - **If you cannot reach your gas supplier, call the fire department.**
- **Installation and service must be performed by a qualified installer, service agency or the gas supplier.**

ATTENTION USER: Before operating this appliance, read all the instructions contained within this manual. Retain this manual for future reference.

SECTION	TABLE OF CONTENTS	PAGE
WARNING	What to do if you smell gas	Front Cover
SECTION 1	Recording rating plate and other information	3
SECTION 2	Combustion Air & Venting	3
SECTION 3	Important safety precautions, read before operating	3
SECTION 4	Return Air Duct & Return Air Filter	4
SECTION 5	Understanding how your heating system works	4
SECTION 6	Operating your furnace	4
SECTION 7	Turning off your furnace in an emergency	5
SECTION 8	Operating your air conditioning	6
SECTION 9	Maintenance of your unit	6
SECTION 10	Before requesting a service call	8
SECTION 11	Parts Lists	9

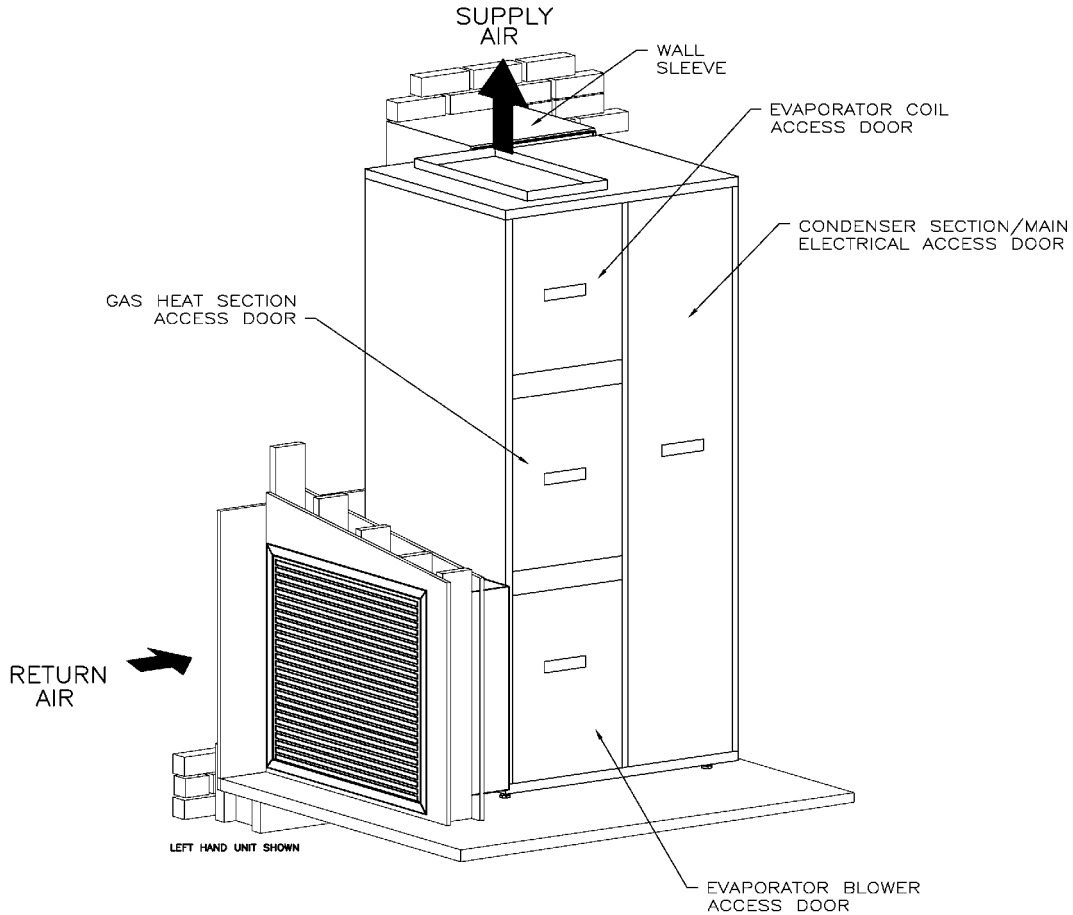

LD13220A

SECTION 1. RECORDING RATING PLATE & OTHER INFORMATION

Record the furnace model number and serial number below. These are on your furnace rating plate located on blower door. Record installation date, which is important for warranty purposes.

Also fill in the installer's name, address and telephone number. This will be handy if you have questions later. Some companies install an identification tag on furnaces they install or service. If not, ask for the information.

YOUR FURNACE INFORMATION

Model Number: _____

Serial Number: _____

Date Installed: _____

Installer/Service Agency: _____

Address: _____

City/State/Zip Code: _____

Telephone Number: _____

SECTION 2. COMBUSTION AIR & VENTING

The Skypak gas furnace is a direct vent appliance which is equipped with a built-in venter blower. All air required for proper combustion is drawn in from the outdoors through the wall sleeve and grille which the furnace is attached to. There is no need for any other provision for combustion air to get into the room where the furnace is installed. The products of combustion are exhausted directly to the outdoors through small rectangular duct 2 3/4 in. x 1 3/4 in. which extends through the wall sleeve from the back of the unit and terminates 1 to 1 1/4 in. from the back of the grille in the outside wall. This small exhaust duct extension has to be installed by the contractor when the furnace is installed. The furnace must not be operated without this exhaust duct extension being installed. The exhaust from the Skypak furnace must not be connected to any other vent pipe or chimney. All access doors must be installed for this direct vent furnace to operate properly and safely.

SECTION 3. IMPORTANT SAFETY PRECAUTIONS

Read Before Operating

1. Ask the installer to verify that the exhaust duct extension is properly installed as described above, if you cannot see it by looking through the top right corner of the wall grille.

2. Never allow the furnace to be operated without all the access doors installed.
3. These furnaces draw air for combustion through the exterior wall grille. For proper and safe operation, make sure the exterior grille is kept clear of any obstructions to air flow.
4. This furnace requires an adequate ventilation air supply for proper and safe operation. Do not block or obstruct any air openings connecting to the area in which the furnace is installed.
5. The furnace area must be kept clear and free of combustible materials, gasoline and other flammable vapors and liquids. These include kerosene, cleaning fluids, solvents, paint thinner or paint.
6. Keep the clearance spaces around the furnace free and clear of insulating material. Examine the furnace area after the initial installation, and re-examine if additional insulation is added in the furnace area. Some insulating materials may be combustible.
7. Become familiar with the sequence of operation, and how to safely turn on and turn off your furnace, as described in Section 6.
8. Should the gas supply fail to shut off or if overheating occurs, shut off the gas valve to the furnace before shutting off the electrical supply. Learn where and how to shut off the gas and the electric power to the furnace. Ask the installer to show you how to do this. Further details on how to do this are given in Section 7.
9. Do not use this furnace if any part has been under water. A flood damaged furnace is extremely dangerous. Attempts to use the furnace can result in fire or explosion. A qualified service agency should be contacted to inspect the furnace and to replace all gas controls, control system parts, electrical parts that have been wet or the furnace if deemed necessary.
10. Inspect and replace return air filters as recommended in Section 4 of this manual.
11. The furnace is equipped with both temperature and pressure switches to shut off the furnace if unsafe operating conditions occur. These safety switches must not be altered in any way. Call a qualified service agency if problems occur.

12. Prior to each heating season, the following specific items should be checked annually:
- The flue gas exhaust duct outlet (visible behind the upper right corner of the exterior wall grille) is clear and free of obstruction.
 - The return-air duct connection(s) is physically sound, is sealed to the furnace casing, and terminates outside the space containing the furnace.
 - The physical support of the furnace is sound without sagging, cracks, gaps, etc., around the base so as to provide a seal between the support and the base.
 - An overall physical inspection confirms that there are no obvious signs of deterioration (corroded electrical connections, fluid stains, signs of rust, excess accumulation of dirt or debris).
 - The pilot and burner flames are in good adjustment as described in Section 9.

SECTION 4. RETURN AIR DUCT & FILTER

A return air duct must be sealed to the unit casing and the return air duct must terminate outside the space containing the furnace. All air returning to the furnace must be filtered. The filter rack is usually installed where the return air duct is connected to the furnace. A filter is not supplied with the furnace. The filter is to be supplied and installed by the installing contractor. Replacements filters must be the same size and type as the original. When the factory supplied side return filter rack is used, the filter required is a disposable fiberglass filter having a nominal size of 18 in. high x 25in. wide x 1 in. thick. The filter can be slid into or out of the filter rack. Tools are not required to examine or replace the filter. It is recommended that filters be inspected monthly, until it is found how long it takes for the filter to become dirty enough to require replacing. It is a good policy to replace filters at least twice a year.

SECTION 5. UNDERSTANDING HOW YOUR HEATING SYSTEM WORKS

When your indoor temperature drops below the temperature set on your thermostat, the thermostat turns your furnace on as follows:

- Furnace operation begins with the starting of the small venter blower, which induces the flow of combustion air through your furnace's heat exchanger.
- When the flow of combustion air is sufficient for proper combustion, a pressure switch turns on the ignition system. The ignition systems ignites a pilot flame which in turn lights the main burners. The flames from the main burners are pulled through the inside of the heat exchanger, heating the serpentine tube assembly.
- Thirty seconds after the main the main burners light, a computerized control turns on your circulating blower. The circulating blower pulls air through your cold air return and your air filter and then pushes it across the outside of the heat exchanger.
- As the air passes over the heat exchanger, the heat transfers from the heat exchanger to the air being blown across it. The heated air is then returned to your house through your registers.
- During operation, your furnace is monitored constantly by a series of safety controls and temperature limit switches, which act to turn off the furnace if any unsafe condition occurs.
- The furnace's burners operate until your room temperature reaches the setting on the thermostat. After the burners turn off, the circulating blower continues to operate for one minute in order to remove the remaining heat from the heat exchanger and duct system.

SECTION 6. OPERATING YOUR FURNACE



If you do not follow these instructions exactly, a fire or explosion may result causing property damage, personal injury or loss of life.

- This appliance is equipped with an ignition device which automatically lights the pilot and the main burners. Do not try to light the pilot and main burners by hand.
- BEFORE OPERATING smell all around the appliance area for gas. Be sure to smell next to the floor because some gas is heavier than air and may have settled on the floor.

STARTING YOUR FURNACE

1. **STOP!** Read the safety information preceding this steps.
2. Set the thermostat to its lowest setting.
3. **Close** (GAS OFF) the external manual gas valve (located in the gas supply pipeline, adjacent to the furnace).



Figure 1 - Typical Furnace External Manual Gas Valve

NOTE: In the Commonwealth of Massachusetts a t-handle gas cock must be installed.

4. Turn **OFF** all electrical power to the furnace.
5. This furnace is equipped with an ignition device which automatically lights the pilot and the main burners. Do **not** try to light the pilot and main burners by hand.
6. Remove the largest of the access doors on the furnace.
7. Locate the gas control valve in the gas pipe and move the on/off slide switch to the OFF position, as shown in the illustration.

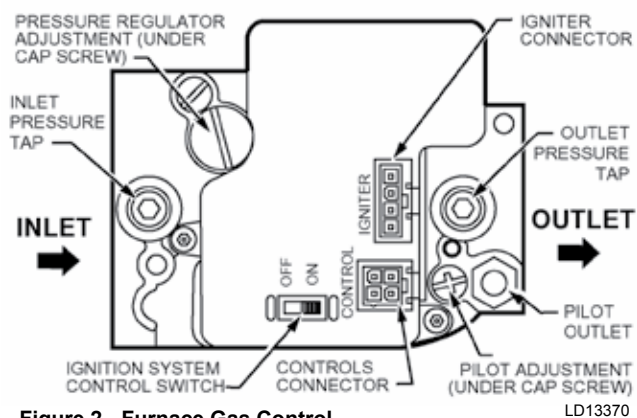

Figure 2 - Furnace Gas Control

8. Wait five (5) minutes to clear out any gas. Then smell for gas, including near the floor. **If you smell gas, STOP!** Follow the safety instructions on the front cover of this manual, "What to do if you smell gas." If you do not smell gas, go to the next step.

9. Move the slide switch on the gas control valve to the **ON** position.
10. Replace the access door on the furnace.
11. Turn **ON** the electrical power to the furnace.
12. Open (GAS ON) the external manual gas valve.
13. Set room thermostat to a setting slightly above room temperature. This will automatically signal the furnace to start.
14. Furnace operation begins with the starting of the small venter blower, which induces the flow of combustion air through your furnace's heat exchanger. The hot surface igniter will glow bright orange to light the small pilot flame. Once the ignition system detects that the pilot flame has been established, the gas valve permits gas to flow to the main burners where it is ignited by the pilot flame.

If the main burners fail to ignite on the first trial, the furnace control system will go through 2 more ignition cycles. If the burners fail to ignite after 3 trials, the system will lockout.

If lockout occurs, or the main circulating air blower fails to turn on - shut down your furnace and call your qualified service technician or gas supplier.

SECTION 7. SHUTTING OFF YOUR FURNACE

Should you ever suspect a malfunction in your furnace, you will need to turn the furnace **OFF**. The following procedures must be followed.



Should overheating occur or the gas valve fail to shut off the gas supply, turn off the manual gas valve (See Fig.3) to the furnace BEFORE turning off the electrical supply. Failure to follow these instructions exactly may result in a fire or explosion, causing property damage, personal injury or death.

1. Set the room thermostat to the lowest temperature setting.
2. The gas supply to the furnace can be turned off at the manual shut off valve in the gas pipe just before where the pipe enters the furnace.

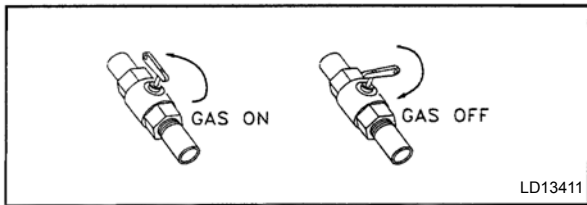

Figure 3 - Typical Furnace External Manual Gas Valve

NOTE: IN THE COMMONWEALTH OF MASSACHUSETTS
A T-HANDLE GAS COCK MUST BE INSTALLED

If you are not able to turn off the external manual shut off valve outside the furnace, turn off the gas supply with the main shut off valve at the gas meter outside the house. If the furnace operates on propane, close the shut off valve on the propane cylinder. The following illustration shows a typical shut off valve in the open and closed positions.

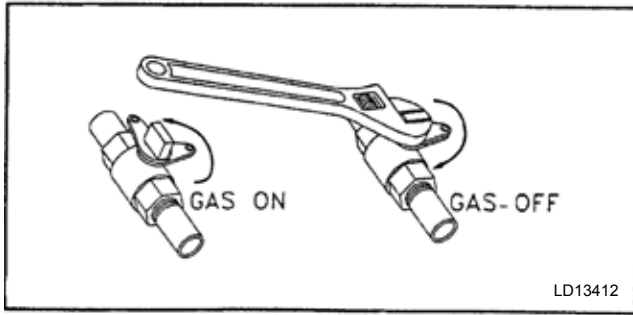

Figure 4 - Typical Gas Meter Gas Valve

3. Turn **OFF** all electrical power to the furnace.

If you are unable to turn off the electrical supply using the disconnect switch near the furnace, you can turn off the electrical power to the furnace by using the circuit breaker that supplies the furnace from the main electrical panel.

4. Remove the largest access door on the furnace which is nearest to where the gas pipe enters the furnace.
5. Move the slide switch on the gas control valve to the OFF position (See Fig.2).
6. Replace the access door.
7. If the furnace is being shut down because of a malfunction, call your qualified service technician or gas supplier as soon as possible.

SECTION 8. OPERATING YOUR AIR CONDITIONING

1. Make sure the electric power is turned on at the disconnect.
2. Set the room thermostat to the desired temperature.
3. Move the system selector switch on the thermostat to the COOL position.
4. Move the fan switch on the thermostat to the AUTO position. The compressor and condenser fan should then start as soon as the thermostat is calling for cooling. After a short delay of four seconds the blower will start to circulate cool air. When the room temperature drops to the setting on the room thermostat, the compressor and condenser fan will stop immediately. The blower will continue running or another 100 seconds to extract all of the cooling available from the cooling coil and then stop until the next cycle begins.

SECTION 9. MAINTENANCE OF YOUR UNIT

A furnace is not a simple household appliance. It is a complex mechanical assembly and requires professional maintenance and repair.

Other than performing the simple maintenance recommended in this manual, you should not attempt to make any adjustments to your furnace. A periodic inspection of your furnace should be made by a qualified service agency at the start of each heating season.

With proper maintenance and care, your furnace will operate economically and dependably. Basic maintenance procedures, which can be accomplished by someone who follows directions, are found on the following pages.



ELECTRICAL SHOCK, FIRE OR EXPLOSION HAZARD

Failure to follow safety warnings exactly could result in dangerous operation, serious injury, death or property damage.

Improper servicing could result in dangerous operation, serious injury, death or property damage.

- Before servicing, disconnect all electrical power to the furnace.
- When servicing controls, label all wires prior to disconnecting. Reconnect wires correctly.
- Verify proper operation after servicing

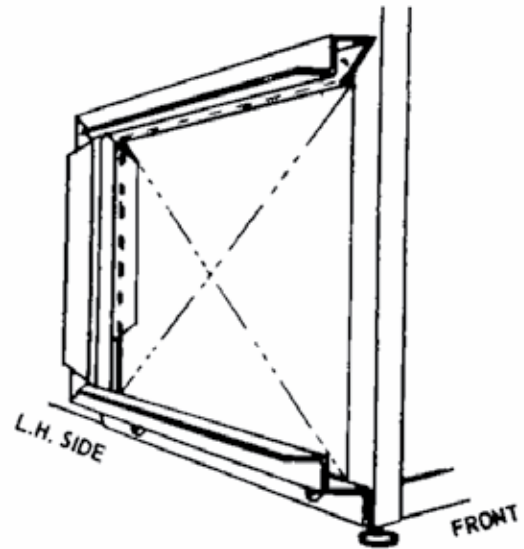

LD13226

A. FILTER MAINTENANCE

A dirty filter will cause excessive stress on the furnace, heat exchanger, and blower motor and can cause it to overheat and automatically shut down. The furnace filter should be checked every 4 weeks or so, and cleaned or replaced as necessary.

If your furnace filter needs replacing, be sure to use the same size and type of filter that was originally specified.



Never operate your furnace without a filter in place. Doing so may damage the furnace blower motor. An accumulation of dust and lint on internal parts of your furnace can cause a loss of efficiency

The air filter for the furnace will normally be installed in a slide-in rack, immediately external to the furnace casing. If the air filter has been installed in another location, contact your service dealer for instructions.

When the factory supplied side return filter rack is used, the filter required is a disposable fiberglass filter having a nominal size of 18 in. high x 25in. wide x 1 in. thick. The filter can be slid into or out of the filter rack. Tools are not required to examine or replace the filter.

It is recommended that the furnace be inspected once a year by a qualified service technician. Annual inspections should include checking the following:

B. GENERAL INSPECTION

Examine the furnace installation for the following items.

- i. The wall grille must be clear of any obstructions that could restrict airflow into the unit or cause exhaust to be recirculated.
- ii. The exhaust vent extension pipe must be in place and terminating within 1 1/4 inch from the back of the wall grille. The vent pipe and vent pipe extension must be physically sound without holes or excessive corrosion.
- iii. The return air duct should be physically sound, sealed to the furnace casing, and terminate outside the space containing the furnace.
- iv. The physical support of the furnace must be sound without sagging, cracks, gaps, etc. around the base so as to provide a seal between the support and the base.
- v. There must be no obvious signs of deterioration of the furnace.

C. BLOWERS

The blower size and speed determine the air volume delivered by the furnace. Both the indoor and outdoor blower motors, and the exhaust vent blower motor, all feature permanently lubricated that do not require oiling.

Annual cleaning of the blower wheel and housing is recommended for maximum air output; this should be performed only by a qualified servicer or service agency.

D. IGNITER & BURNERS

These furnaces use a special hot surface igniter to light the pilot burner. Please note that this assembly is very fragile and should only be handled with care.



Do not touch igniter. It can be extremely hot.

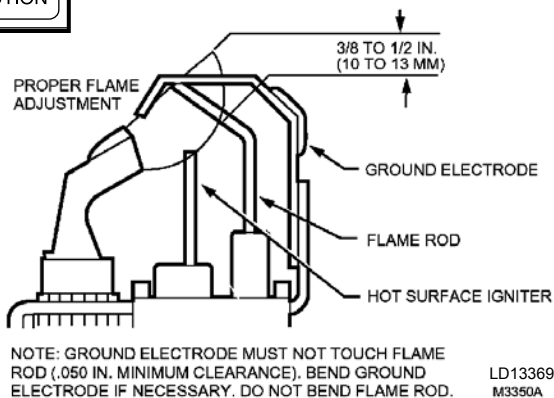
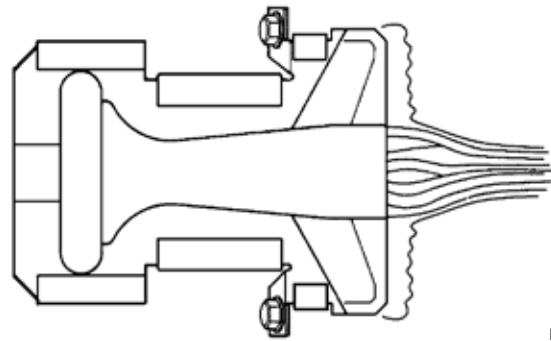

Figure 5 - Pilot Burner

Gas burners do not normally require scheduled servicing. However, accumulations of dirt, soot, or rust and result in a loss of efficiency and improper performance. The pilot and burner flames should be in good adjustment as shown in figures 5 and 6. The main burner flames should be clear blue and centered within the heat exchanger openings. Any yellowing of the burner flames indicates that cleaning and/ or adjustment of the burners is required. For best operation, burners should be cleaned annually using brushes and a vacuum cleaner.

Significant buildups on the main burners can cause faulty firing. 'Delayed ignition' is characterized by a loud noise when the main burners are ignited. This condition indicates that a service call is required as soon as possible.



LD13413

Figure 6 - Main Bruner

SECTION 10. BEFORE REQUESTING A SERVICE CALL

If your furnace is operating but not heating your house:

1. Check your air filter by following the instructions in the air filter section of this manual.
2. Check registers and return air grilles. They should be open, clean, and unobstructed.
3. Make sure your thermostat is in the HEAT position.
4. Make sure your thermostat is set above the room temperature.
5. Make sure your thermostat is not near a heat source such as a lamp, television, computer, direct sunlight or a fireplace.
6. Make sure your gas is ON.
7. If your furnace still fails to provide sufficient heat, call a qualified service technician. Have your furnace model and serial number ready.

If your furnace does not operate at all:

1. Make sure your thermostat is in the HEAT position.
2. Make sure your thermostat is set above the room temperature.
3. Check for blown fuses or tripped circuit breakers.
4. Make sure your gas is ON.
5. If your furnace still fails to operate, call a qualified service technician. Have your furnace model number and serial number ready.

LIMITED WARRANTY – RGAC, SGAC FURNACE / AIR CONDITIONER

Johnson Controls warrants this product to be free from defects in workmanship or material for a period of one year from date of original installation of 18 months from date of shipment.

Johnson Controls obligation under this Warranty is LIMITED to repairing or replacing at our sole option, at our factory, any part thereof which shall be returned to our factory, transportation charges prepaid and which on examination proves to have been thus defective under normal domestic use not exceeding the fuel rating. The defective part should be returned through a qualified servicing dealer. Upon warranty determination, the replacement part will be shipped freight collect and assumes the unexpired portion of this Limited Warranty.

When a defective part can be repaired or replaced, Johnson Controls shall not be obligated to repair the entire unit or any part thereof other than the defective part.

This warranty applies only to the original homeowner, and is subject to the terms and conditions hereof.

COMPRESSOR – FIVE YEAR LIMITED WARRANTY

In addition to the One Year Limited Warranty, Johnson Controls warrants the compressor to be free from defects in workmanship or material for a period of five (5) years from the date of original installation. If a compressor fails during this five year period, a new compressor will be supplied. The customer will be responsible for freight costs from our factory for delivery of the replacement compressor and also for the return of the defective compressor which may be required under the terms of the Warranty. Labor and any other expense involved in replacing the compressor is not covered by this Warranty.

HEAT EXCHANGER – TEN YEAR LIMITED WARRANTY

In addition to the One Year Limited Warranty, Johnson Controls warrants the heat exchanger to be free from defects in workmanship for a period of ten (10) years from the date of original installation. During this time, a new replacement heat exchanger will be furnished, or at our sole option, a credit for the replacement heat exchanger may be allowed. Labor and other expenses involved in replacing the heat exchanger are not covered by this warranty. This Warranty applies only to the heat exchanger and not to other parts of the furnace, and only to the original homeowner, and is subject to the terms and conditions hereof.

LABOR AND COST NOT COVERED

This Warranty provides only replacement parts or credits, and does not provide for or cover any labor, shipping, handling or other costs for service travel, servicing, removing, or installing any parts.

EXCLUSIONS

This Warranty shall be void if:

1. The unit is not installed by a licensed or otherwise qualified contractor and in compliance with the Installation Manual, applicable installation and good trade practices.
2. The defect or damage is caused by accident, abuse, negligence of any person or company, misuse, riot, flood, fire or Acts of God.
3. The unit is not operated and regularly serviced and maintained as called for in the Users' Manual.
4. Damages are caused by operating the unit in a commercial or corrosive atmosphere containing any damaging or dangerous chemicals.
5. The unit is modified or serviced in a manner not in accordance with the Installation Manual and Users' Manual.
6. Components, replacement parts, or other accessories not compatible with the unit or not approved by Johnson Controls have been used with or attached to the unit.
7. The defect or damage is not caused by Johnson Controls, or it arises from circumstances beyond the control of Johnson Controls.
8. The unit is installed outside the United States or Canada, or has been removed from the place where it was originally installed.

THIS WARRANTY IS IN LIEU OF ALL OTHER WARRANTIES, OBLIGATIONS OR LIABILITIES, EXPRESSED OR IMPLIED BY EMPLOYEES OR REPRESENTATIVES OF JOHNSON CONTROLS. ALL STATUTORY, EXPRESSED OR IMPLIED WARRANTIES, INCLUDING THE IMPLIED WARRANTY OF MERCHANTABILITY AND FITNESS FOR A PARTICULAR PURPOSE ARE HEREBY NEGATED AND EXCLUDED. ANY CLAIMS FOR INCIDENTAL AND CONSEQUENTIAL DAMAGES, OR ANY OTHER DAMAGES OR EXPENSES BEYOND THE TERMS OF THIS LIMITED WARRANTY ARE HEREBY EXPRESSLY NEGATED AND EXCLUDED.

