

**Model REAC / SEAC
Self Contained Cooling /
Electric Heating Units**

Supersedes: 145.30-IOM1 (708)

Form 145.30-IOM1 (908)

**UNIT MODELS
REAC / SEAC - R22
ELECTRIC HEATING / ELECTRIC COOLING
INSTALLATION, OPERATION
& MAINTENANCE INSTRUCTIONS**

Cooling Capacities

12,000, 18,000, 24,000, & 30,000 Btu/Hr.

Heating Coil Capacities

2.5, 5, 7.5, 10 & 15 Kw. - Heating



IMPORTANT!

READ BEFORE PROCEEDING!

GENERAL SAFETY GUIDELINES

This equipment is a relatively complicated apparatus. During installation, operation, maintenance or service, individuals may be exposed to certain components or conditions including, but not limited to: refrigerants, oils, materials under pressure, rotating components, and both high and low voltage. Each of these items has the potential, if misused or handled improperly, to cause bodily injury or death. It is the obligation and responsibility of operating/service personnel to identify and recognize these inherent hazards, protect themselves, and proceed safely in completing their tasks. Failure to comply with any of these requirements could result in serious damage to the equipment and the property in

which it is situated, as well as severe personal injury or death to themselves and people at the site.

This document is intended for use by owner-authorized operating/service personnel. It is expected that this individual possesses independent training that will enable them to perform their assigned tasks properly and safely. It is essential that, prior to performing any task on this equipment, this individual shall have read and understood this document and any referenced materials. This individual shall also be familiar with and comply with all applicable governmental standards and regulations pertaining to the task in question.

SAFETY SYMBOLS

The following symbols are used in this document to alert the reader to areas of potential hazard:



DANGER indicates an imminently hazardous situation which, if not avoided, will result in death or serious injury.



CAUTION identifies a hazard which could lead to damage to the machine, damage to other equipment and/or environmental pollution. Usually an instruction will be given, together with a brief explanation.



WARNING indicates a potentially hazardous situation which, if not avoided, could result in death or serious injury.

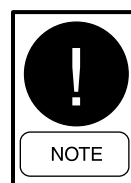

NOTE is used to highlight additional information which may be helpful to you.



All wiring must be in accordance with published specifications and must be performed ONLY by qualified service personnel. Johnson Controls will not be responsible for damages/problems resulting from improper connections to the controls or application of improper control signals. Failure to follow this will void the manufacturer's warranty and cause serious damage to property or injury to persons.

CHANGEABILITY OF THIS DOCUMENT

In complying with Johnson Controls policy for continuous product improvement, the information contained in this document is subject to change without notice. While Johnson Controls makes no commitment to update or provide current information automatically to the manual owner, that information, if applicable, can be obtained by contacting the nearest Johnson Controls service office.

It is the responsibility of operating/service personnel as to the applicability of these documents to the equipment in question. If there is any question in the mind of operating/service personnel as to the applicability of these documents, then, prior to working on the equipment, they should verify with the owner whether the equipment has been modified and if current literature is available.



Work on this equipment should only be done by properly trained personnel who are qualified to work on this type of equipment. Failure to comply with this requirement could expose the worker, the equipment and the building and its inhabitants to the risk of injury or property damage.

The instructions are written assuming the individual who will perform this work is a fully trained HVAC & R journeyman or equivalent, certified in refrigerant handling and recovery techniques, and knowledgeable with regard to electrical lock out/tag out procedures. The individual performing this work should be aware of and comply with all national, state and local safety and environmental regulations while carrying out this work. Before attempting to work on any equipment, the individual should be thoroughly familiar with the equipment by reading and understanding the associated service literature applicable to the equipment. If you do not have this literature, you may obtain it by contacting a Johnson Controls Service Office.

Should there be any question concerning any aspect of the tasks outlined in this instruction, please consult a Johnson Controls Service Office prior to attempting the work. Please be aware that this information may be time sensitive and that Johnson Controls reserves the right to revise this information at any time. Be certain you are working with the latest information.

REAC and SEAC models provide a complete air-conditioning and heating system as an all-in-one package. Specifically designed for convenient through-the-wall installation in residential low and high rise applications. The all-indoor design eliminates the need for unsightly exterior equipment, thereby maintaining architectural esthetics.

All units are shipped completely wired and factory tested. The cooling section features enhanced refrigeration coils, a thermostatic expansion valve for refrigerant control, and a high efficiency Scroll or rotary compressor. Air circulating fans are centrifugal, direct driven. The evaporator fan motor allows operation at three different fan speeds.

The standard unit may be operated on the cooling cycle at outdoor ambient above 60°F.

TABLE OF CONTENTS

PREPARING TO INSTALL UNIT	6
IMPORTANT SAFETY RULES.....	6
MEETING CODES	6
UNPACKING	6
INSTALLATION	6
CLEARANCES	6
WALL OPENING	6
WALL SLEEVE	6
UNIT TO SLEEVE ATTACHMENT.....	7
INSTALLING DUCTWORK.....	8
FILTER RACK INSTALLATIONS FOR SIDE RETURN	9
CONDENSATE DRAIN PIPING	10
ELECTRICAL CONNECTIONS.....	11
INSTALLING ELECTRICAL WIRING	11
SEQUENCE OF OPERATION	11
FURNACE SECTION START-UP CHECKLIST.....	13
SYSTEM BALANCE	14
MAINTAINING UNIT IN GOOD WORKING ORDER.....	14
REFRIGERANT CHARGES	16
SCHEMATIC WIRING DIAGRAM	16
WARRANTY POLICY	19

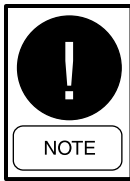

To assure both safe and proper operation, please carefully follow the instructions in this manual to correctly install this new furnace.

INSTALLER! After installing furnace, give the user:

- Operation & Installation Instructions
- Warranty Information

USER! Your furnace installer should give you the above documents relating to your furnace. Keep these as long as you keep your furnace. Pass these documents on to later furnace purchases or Users. Throughout this Installer's Information Manual, we frequently use the word "you" when referring to the person responsible for application, installation and service of your furnace. Please remember to have only qualified service technicians perform these services.

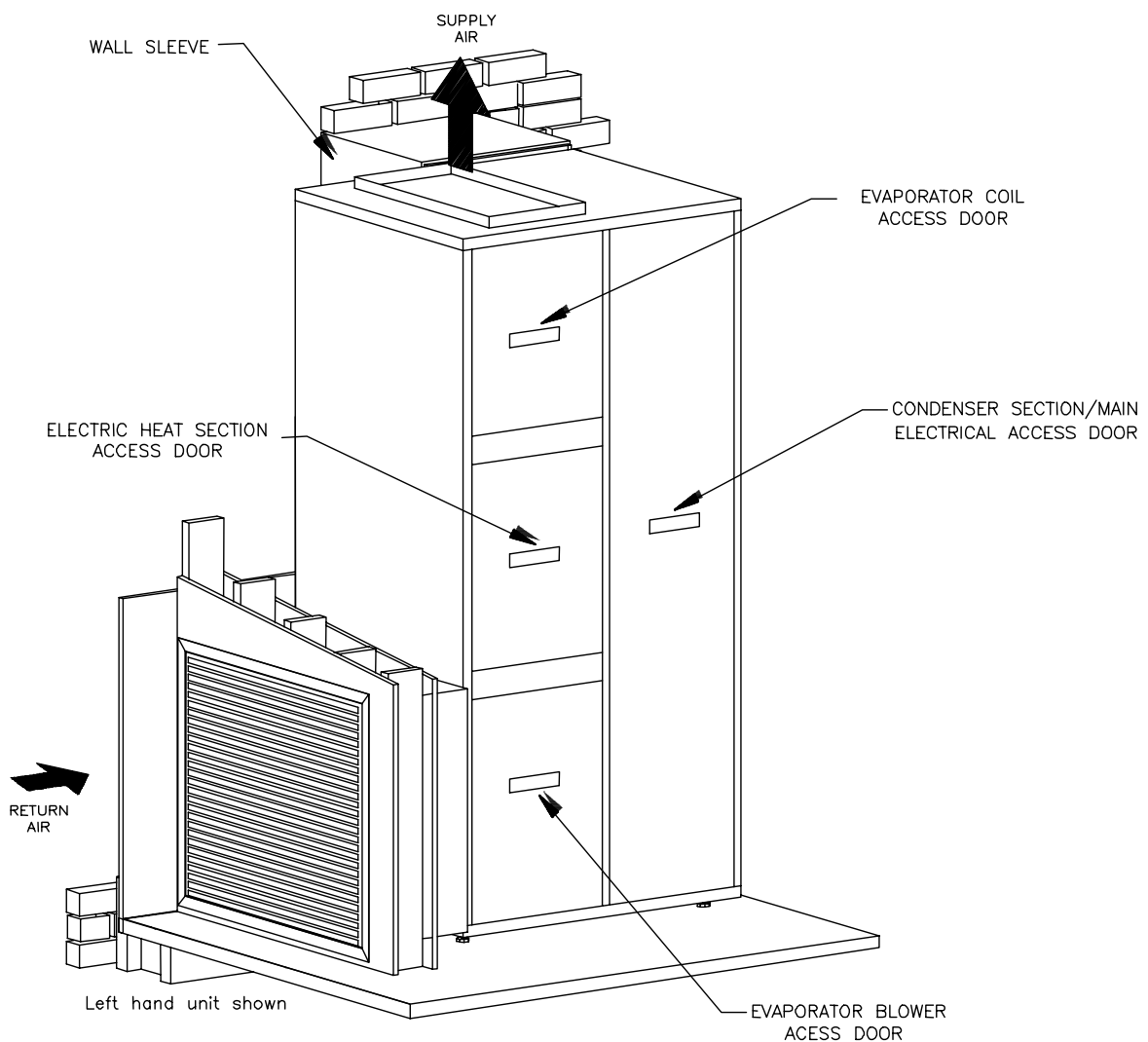

After installing the furnace, show the user how to turn off the electricity to furnace. Point out control and switch locations for turning off the electricity. Make sure user understands the importance of following all safety precautions.

1. PREPARING TO INSTALL FURNACE

A. Literature

Review this Manual and the Users' Manual Information.

After installing the furnace; give this Installer's Information Manual, the Users' Information Manual, and the Warranty card to the end user. If you need help on any of the installation instructions or other matters relating to the furnace, contact the office where you bought the furnace. You may also refer to the furnace rating plate for a contact name.

2. IMPORTANT SAFETY RULES



Signal words: To alert you to potential hazards, we use the signal words "WARNING" and "CAUTION" throughout this manual. "WARNING" alerts you to situations that could cause serious injury or death. "CAUTION" alerts you to situations that could cause minor or moderate injury or property damage. To help you, we use the words "must" and "should" in this manual. "Must" is mandatory. "Should" is advisory.

- a) **DO NOT** install this furnace outdoors or in a mobile home, trailer or recreational vehicle. It is not design-certified for these installations. This furnace is suitable for a home built on site or manufactured home completed at final site.
- b) **DO NOT** install furnace in a corrosive or contaminated atmosphere.
- c) **DO NOT** use this furnace for temporary heating of buildings or structures under construction.
- d) Always install duct system with furnace. Be sure duct system has external static pressure within allowable furnace range.
- e) Completely seal supply and return air ducts to furnace casing. Duct work must run to an area outside furnace air space. Seal duct work whenever it runs through walls, ceilings or floors. See Section 13 for more information.

3. MEETING CODES

Before installing furnace, make sure you know all applicable codes. National, state and local codes may take precedence over any instructions in this manual. Be sure to consult:

- Authorities having jurisdiction over furnaces.
- Local code authorities for information on electrical wiring.

4. UNPACKING

- a) Check the unit for indications of damage in shipment. Notify the Transportation company of any damage and note the damage on the shipping receipt.

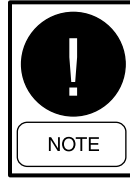

Rough handling may dislocate internal components.

- b) Allow the shipping base to remain with the unit until it is ready to be set in its final location.
- c) Rotate blowers to assure free movement.
- d) The compressor is mounted on neoprene isolators with metal spacing sleeves inside and secured with nuts which must be snug against the metal spacer sleeves.
- e) Check all refrigeration tubing to assure that it does not rub against any other parts.

5. NORMAL INSTALLATION

This unit is designed for indoor installation adjacent to an outside wall having an opening for condenser air flow. The air flow products must:

- A. Discharge directly to the outside.
- B. Discharge away from any obstructions which could cause discharged air recirculation.

6. CLEARANCES

The unit is design certified for closet installation with the minimum clearances to combustible materials as stated on the data label. No clearance is required from the top, sides, or back of the unit. A minimum of 1 inch clearance is required from the front to any combustible materials. A combustible door may be placed 1 inch from the front of the unit. When the door is open there must be 30 inches clearance to any obstruction, to allow sufficient access for service and the replacement of parts. The unit shall not be installed directly on carpeting, tile or other combustible material other than wood flooring.

7. WALL OPENING

A finished opening in an outside wall is required for intake and exhaust of condenser airflow. The wall opening required is 16" wide by 56" high for R models and 16" wide by 63" high for S models. The wall opening must be flush with the finished floor.

Consult local ordinances for building opening framing requirements.

8. WALL SLEEVE

A wall sleeve is required to finish the wall opening. A factory-made wall sleeve is available as an optional accessory for new construction. When replacing a FEDDERS unit with a retrofit model "R", the unit will mate with the existing FEDDERS wall sleeve. Use a spirit level or plumb line to make sure that the wall sleeve vertical flanges, which must mate with the back of the unit, are perfectly vertical. Correct this if necessary, or the unit will not seal properly against the wall sleeve. A roll of 1 inch wide x ¼ inch thick self adhesive rubber gasket is packed in the blower compartment of the Skypak unit, to be used for sealing between the wall sleeve and the unit. Before moving the unit into final position, apply self-adhesive sponge rubber gasket to all the mating flanges on the wall sleeve, be sure to apply gasket material to the divider panel flange between the top and bottom sections of the wall sleeve. Also apply gasket material to the top surface of the horizontal lip at the bottom of the wall sleeve.

9. EXTERIOR GRILLE

Finish the sleeve exterior with a factory supplied intake and discharge grille.

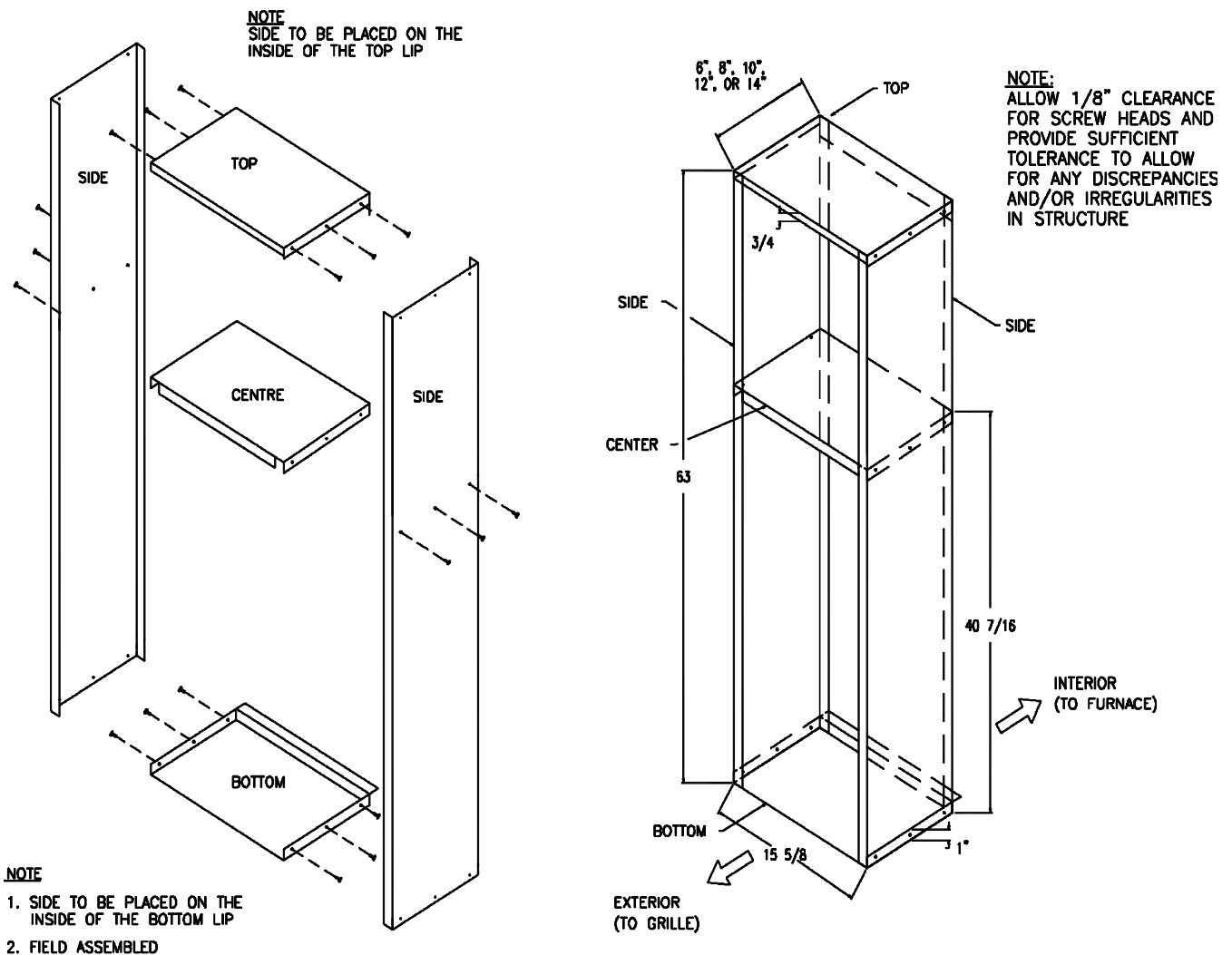

FIG. 1 - WALL SLEEVE ASSEMBLY

LD13574

10. UNIT TO SLEEVE ATTACHMENT

Raise the unit by screwing down the three leveling legs, until the flange at the bottom of the condenser is above the flange at the bottom of the wall sleeve. Then move the unit forward until the unit contacts the wall sleeve and makes a seal with the gasket on the wall sleeve. Then lower the unit by means of the three leveling legs until the unit bottom flange is resting on the wall sleeve bottom flange and the gasket is compressed. Then use the front two leveling screws only to level the unit.

The "S" series units are secured to the wall sleeve by installing two #10 x 1/2 inch self drilling sheet metal screws through the flange standing up at the back of the unit top. These two screws will screw into the wall sleeve. The "R" series units are secured to the wall sleeve using a piece of angle 1 3/8 inch x 1 3/8 inch x 16 inches long. This angle should be placed on the top of the unit at the back with one flange facing down and clipping over the vertical flange at the top of wall sleeve. Then screw this piece of angle to the top of the unit using two #10 x 1/2 inch self drilling sheet metal screws. The required piece of angle and screws are packed inside the blower compartment of "R" series units.

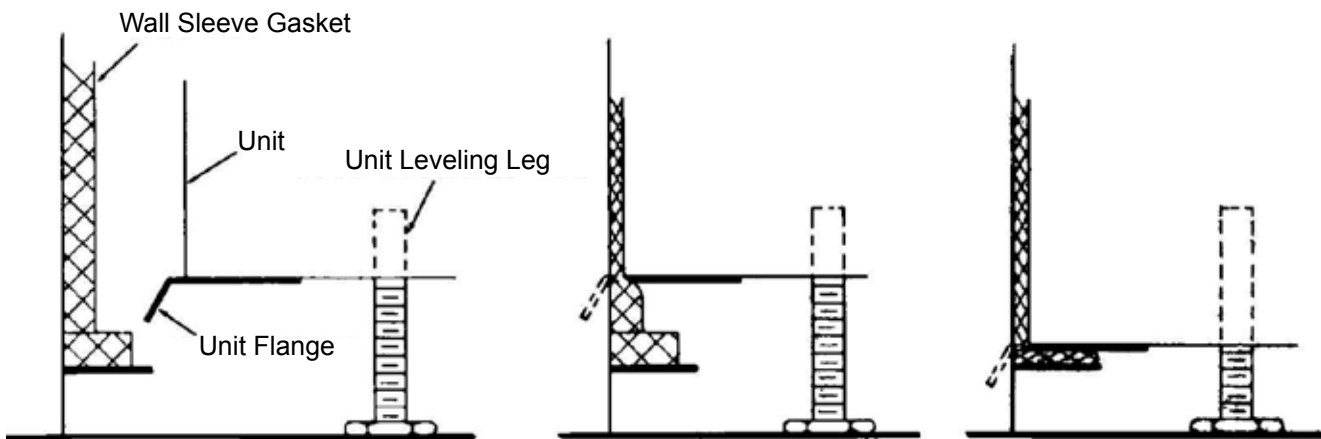
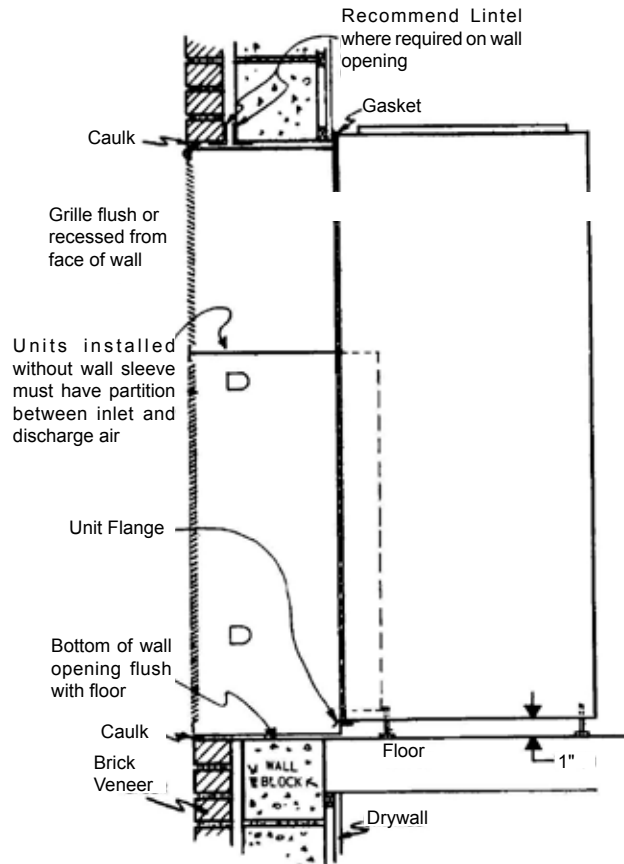

1. Raise unit by means of leveling legs, Unit Flange must clear bottom angle of wall sleeve.
2. Slide Unit into contact with wall sleeve. Unit Flange must be inside wall sleeve.
3. Lower Unit to obtain tight seal between wall sleeve and unit. Insert attachment screws thru blower outlet flange and into wall sleeve..

UNIT/WALL SLEEVE BOTTOM CONNECTION

12. INSTALLING DUCT WORK



Install all duct work to meet current standard:

- ASHRAE/NFPA 90, Standard for Installation of Warm Air Heating and Air Systems.
- State, provincial, and local codes

Failure to follow these standards could reduce air flow or increase air leakage, resulting in reduced system performance or furnace damage.

Properly size duct work based on heat loss and heat gain calculations. Doing so assures:

- Good heating and cooling installations;
- Delivery of required circulating air.

For all furnaces, design duct systems within the maximum external static pressure limits indicated in Table 1.

TABLE 1 - CFM AND MOTOR SPEED SELECTION

UNIT MODEL	SPEED TAP	EXTERNAL STATIC PRESSURE (in. wg.)						
		0.1	0.2	0.3	0.4	0.5	0.6	0.7
SEAC**1212	HIGH	565	540	510	470	420	355	280
	MED-HI	470	455	435	405	365	300	200
	MED-LO	375	370	365	340	300	235	-
	LOW	310	305	285	260	215	-	-
R/SEAC**1812	HIGH	765	735	695	655	600	545	455
	MEDIUM	705	680	650	620	570	505	420
	LOW	530	525	515	500	465	420	345
R/SEAC052412 R/SEAC752412	HIGH	930	910	880	840	780	720	640
	MEDIUM	730	750	740	720	685	635	560
	LOW	500	515	515	500	470	420	340
R/SEAC102412 R/SEAC152412	HIGH	1070	1020	975	910	845	765	660
	MEDIUM	935	910	880	830	785	710	620
	LOW	820	815	800	765	720	660	570
SEAC**3012	HIGH	1070	1020	975	910	845	765	660
	MEDIUM	935	910	880	830	785	710	620
	LOW	820	815	800	765	720	660	570

LD13575

SUPPLY AIR DUCT WORK

Duct attaching hardware must only be used on the supply air outlet flanges. Refrigeration tubing is located under the top panel near these flanges. Do not drill or use screws in this area.



Supply air duct (plenum) connection must be at least the same size as the furnace supply air opening. Seal supply air duct work to furnace casing, walls, ceilings or floors.

RETURN AIR DUCT WORK & FILTERS

All return air entering the unit must be filtered. Refer to Section 15 for filter size and instructions on installing the filter rack. The return air filter must be supplied by the installing contractor. The return duct should be sealed to the unit casing and terminate outside the space containing the furnace.

13. FILTER RACK INSTALLATIONS FOR SIDE RETURN



Air filters are required to keep the air conditioning coil, and blower motor clean. A filter frame has to be field installed, after snipping out the prepunched opening in the side of the unit.

Position the three sided filter frame so that the short side is towards the back of the furnace and the 1 inch duct flange is facing outwards. The long sides of the frame should be pulled slightly towards each other, so that the continuous slip formed on the back of the frame clears the opening in the cabinet. Push the frame towards the back of the unit firmly until the short vertical part of the frame clips onto the cabinet. Then insert the other vertical side of the frame between the ends of the top and bottom parts of the frame. This will keep the top and bottom parts of the frame clipped into position.

If there is difficulty getting the front vertical piece installed. Remove the entire filter frame and trim off any burrs left where the opening was snipped out.

ALTERNATIVE FILTER ARRANGEMENTS

On 1 and 1 ½ ton units only, a filter frame to hold a 14 x 20 x 1 inch disposable filter may be fitted to the front of the blower compartment, in place of the access door. The filter frame and a section of the return duct connected to it must be easily

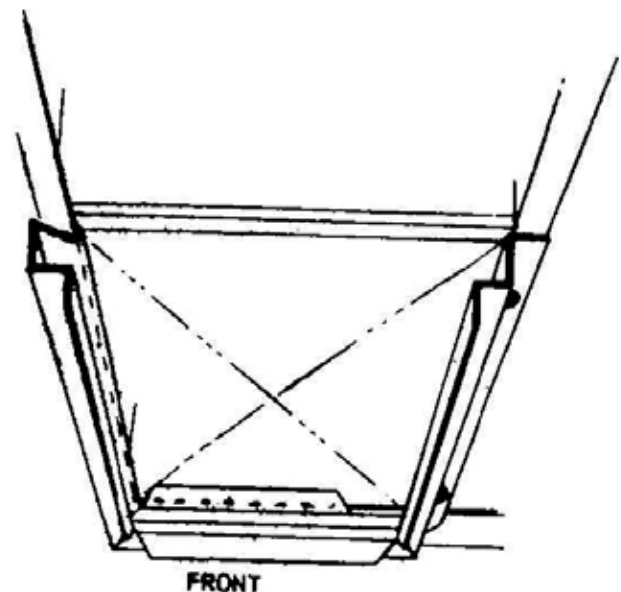
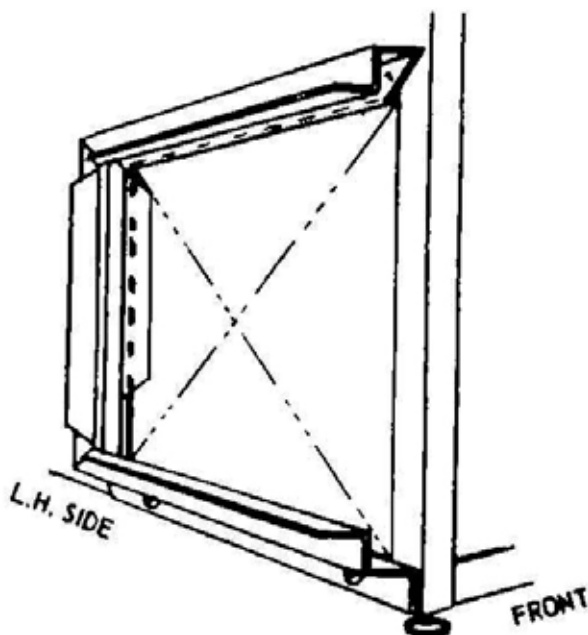

BOTTOM RETURN PLENUMS

When a bottom return plenum is used, snip out the pre-punched 11 x 20 inch opening in the bottom of the cabinet. Do not use this opening as a filter size. Filters must not be installed inside the unit. On bottom return applications, filters must be installed in the bottom return plenum or in the return air duct.

RECOMMENDED FILTERS SIZES FOR BOTTOM RETURN

Unit Size	Filter Size
1 Ton	12" x 20" x 1"
1-1/2 Ton	12" x 25" x 1"
2 Ton	18" x 25" x 1"
2-1/2 Ton	18" x 25" x 1"

There are no filters supplied with this unit. The installing contractor must provide and install the recommended size filters.

14. CONDENSATE DRAIN PIPING

The condensate drain pan is fitted with a 3/4" NPT female pipe fitting which protrudes through the unit casing. The 3/4" drain piping should be run horizontally from this fitting, until the piping is past the side of the unit casing and not passing in front of any of the access doors. Once the piping is clear of the unit casing, a trap should be installed to prevent conditioned air from being blown out of the drain line. The trap should be at least 2 inches deep with the outlet a minimum of 1/2 inch below the inlet. The drain piping on the outlet side of the trap should be pitched 1/4 inch per foot down towards an open drain. Unions should be installed between the unit and the trap, and on the outlet side of the trap to allow for disconnecting the piping and the trap for cleaning out.

15. ELECTRICAL CONNECTIONS

Check the voltage and phase listed on the unit rating plate, before installation, to be sure the power supply is correct. If the compressor fails as the result of installation or improper voltage, the compressor is not replaceable under warranty and the manufacturer will not be responsible for the cost of replacement. The minimum and maximum operating voltages, and fuse sizes, are listed on the unit rating plate.

The power leads must be brought to the entry knockouts provided in the unit control box through a customer supplied fused disconnect switch placed within sight of the unit. Knockouts are provided on the side of all units.

16. INSTALLING ELECTRICAL WIRING



Provide furnace with its own separate electrical circuit, means of circuit protection and electrical disconnect switch. Follow current National Electrical Code ANSI/NFPA 70, CSA C22.1 C.E.C. Part 1, and state and local codes. Failure to provide these shut-off means could cause electrical shock or fire, resulting in damage, injury or death.

Install proper electrical grounding source to green wire conductor in furnace junction box. Follow current National Electrical Code ANSI/NFPA 70 and local codes, or CSA C22.1 Canadian Electrical Code Part 1.



Furnace must have proper electrical ground. Failure to provide a proper electrical ground could cause electrical shock or fire, resulting in damage, injury or death.

TABLE 2 - ELECTRICAL DATA

Unit Model	Comp RLA	Comp LRA	Evap Mtr. HP	Evap Mtr. FLA	Cond Mtr. HP	Cond Mtr. FLA	Heat#1 Input (kW)	Heat#2 Input (kW)	Heat#3 Input (kW)	Min. Circuit Ampacity			Max Overcurrent Protection (Fuse/ Ckt Bkr Amps)			
										208V	230V	240V	208V	230V	240V	
SEAC251212L-A	4.8	26.3	1/10	0.9	1/6	1.1	2.1/2.57/2.8	N/A	N/A	N/A	13.62	14.97	15.58	15	15	20
SEAC251212R-A	4.8	26.3	1/10	0.9	1/6	1.1	2.1/2.57/2.8	N/A	N/A	N/A	13.62	14.97	15.58	15	15	20
SEAC051212L-A	4.8	26.3	1/10	0.9	1/6	1.1	4.21/5.14/5.6	N/A	N/A	N/A	26.30	28.93	30.17	30	30	35
SEAC051212R-A	4.8	26.3	1/10	0.9	1/6	1.1	4.21/5.14/5.6	N/A	N/A	N/A	26.30	28.93	30.17	30	30	35
SEAC751212L-A	4.8	26.3	1/10	0.9	1/6	1.1	4.21/5.14/5.6	2.1/2.57/2.8	N/A	N/A	38.92	42.90	44.75	40	45	45
SEAC751212R-A	4.8	26.3	1/10	0.9	1/6	1.1	4.21/5.14/5.6	2.1/2.57/2.8	N/A	N/A	38.92	42.90	44.75	40	45	45
REAC051812A-A	10	41	1/6	1.2	1/6	1.1	4.21/5.14/5.6	N/A	N/A	N/A	26.80	29.43	30.67	30	30	35
REAC751812A-A	10	41	1/6	1.2	1/6	1.1	4.21/5.14/5.6	2.1/2.57/2.8	N/A	N/A	39.42	43.40	45.25	40	45	50
REAC101812A-A	10	41	1/6	1.2	1/6	1.1	4.21/5.14/5.6	4.21/5.14/5.6	N/A	N/A	52.10	57.37	59.83	60	60	60
SEAC051812L-A	9.3	47	1/6	1.2	1/6	1.1	4.21/5.14/5.6	N/A	N/A	N/A	26.80	29.43	30.67	30	30	35
SEAC051812R-A	9.3	47	1/6	1.2	1/6	1.1	4.21/5.14/5.6	N/A	N/A	N/A	26.80	29.43	30.67	30	30	35
SEAC751812L-A	9.3	47	1/6	1.2	1/6	1.1	4.21/5.14/5.6	2.1/2.57/2.8	N/A	N/A	39.42	43.40	45.25	40	45	50
SEAC751812R-A	9.3	47	1/6	1.2	1/6	1.1	4.21/5.14/5.6	2.1/2.57/2.8	N/A	N/A	39.42	43.40	45.25	40	45	50
SEAC101812L-A	9.3	47	1/6	1.2	1/6	1.1	4.21/5.14/5.6	4.21/5.14/5.6	N/A	N/A	52.10	57.37	59.83	60	60	60
SEAC101812R-A	9.3	47	1/6	1.2	1/6	1.1	4.21/5.14/5.6	4.21/5.14/5.6	N/A	N/A	52.10	57.37	59.83	60	60	60
REAC052412A-A	11.4	56	1/6	1.2	1/4	1.5	4.21/5.14/5.6	N/A	N/A	N/A	26.80	29.43	30.67	30	30	35
REAC752412A-A	11.4	56	1/6	1.2	1/4	1.5	4.21/5.14/5.6	2.1/2.57/2.8	N/A	N/A	39.42	43.40	45.25	40	45	50
REAC102412A-A	11.4	56	1/4	1.5	1/4	1.5	4.21/5.14/5.6	4.21/5.14/5.6	N/A	N/A	52.48	57.74	60.21	60	60	70
REAC152412A-A	11.4	56	1/4	1.5	1/4	1.5	4.21/5.14/5.6	4.21/5.14/5.6	4.21/5.14/5.6	4.21/5.14/5.6	77.78	85.68	89.38	80	90	90
SEAC052412L-A	13.6	61	1/6	1.2	1/4	1.5	4.21/5.14/5.6	N/A	N/A	N/A	26.80	29.43	30.67	30	30	35
SEAC052412R-A	13.6	61	1/6	1.2	1/4	1.5	4.21/5.14/5.6	N/A	N/A	N/A	26.80	29.43	30.67	30	30	35
SEAC752412L-A	13.6	61	1/6	1.2	1/4	1.5	4.21/5.14/5.6	2.1/2.57/2.8	N/A	N/A	39.42	43.40	45.25	40	45	50
SEAC752412R-A	13.6	61	1/6	1.2	1/4	1.5	4.21/5.14/5.6	2.1/2.57/2.8	N/A	N/A	39.42	43.40	45.25	40	45	50
SEAC102412L-A	13.6	61	1/4	1.5	1/4	1.5	4.21/5.14/5.6	4.21/5.14/5.6	N/A	N/A	52.48	57.74	60.21	60	60	70
SEAC102412R-A	13.6	61	1/4	1.5	1/4	1.5	4.21/5.14/5.6	4.21/5.14/5.6	N/A	N/A	52.48	57.74	60.21	60	60	70
SEAC152412L-A	13.6	61	1/4	1.5	1/4	1.5	4.21/5.14/5.6	4.21/5.14/5.6	4.21/5.14/5.6	4.21/5.14/5.6	77.78	85.68	89.38	80	90	90
SEAC152412R-A	13.6	61	1/4	1.5	1/4	1.5	4.21/5.14/5.6	4.21/5.14/5.6	4.21/5.14/5.6	4.21/5.14/5.6	77.78	85.68	89.38	80	90	90
SEAC753012L-A	15	72.5	1/4	1.5	1/3	1.9	4.21/5.14/5.6	2.1/2.57/2.8	N/A	N/A	39.42	43.78	45.63	40	45	50
SEAC753012R-A	15	72.5	1/4	1.5	1/3	1.9	4.21/5.14/5.6	2.1/2.57/2.8	N/A	N/A	39.42	43.78	45.63	40	45	50
SEAC103012L-A	15	72.5	1/4	1.5	1/3	1.9	4.21/5.14/5.6	4.21/5.14/5.6	N/A	N/A	52.48	57.74	60.21	60	60	70
SEAC103012R-A	15	72.5	1/4	1.5	1/3	1.9	4.21/5.14/5.6	4.21/5.14/5.6	N/A	N/A	52.48	57.74	60.21	60	60	70
SEAC153012L-A	15	72.5	1/4	1.5	1/3	1.9	4.21/5.14/5.6	4.21/5.14/5.6	4.21/5.14/5.6	4.21/5.14/5.6	77.78	85.68	89.38	80	90	90
SEAC153012R-A	15	72.5	1/4	1.5	1/3	1.9	4.21/5.14/5.6	4.21/5.14/5.6	4.21/5.14/5.6	4.21/5.14/5.6	77.78	85.68	89.38	80	90	90

LD13576

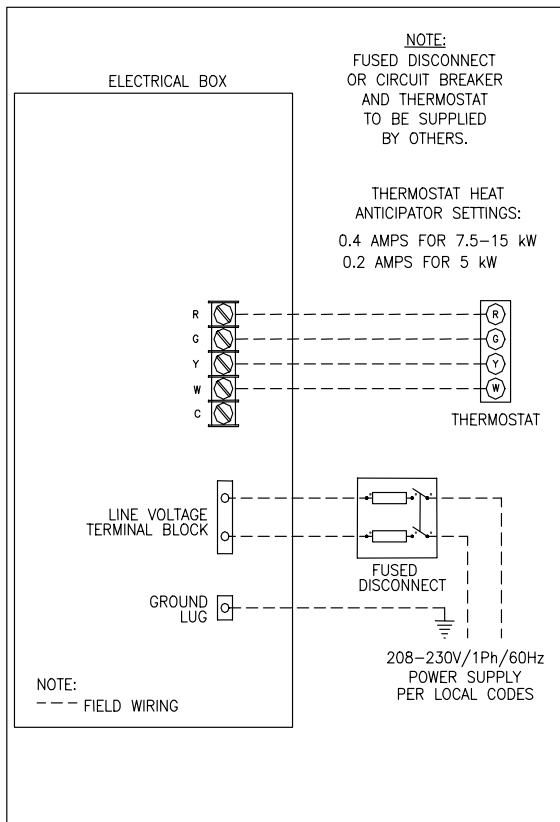

LD13577

FIG. 3 - FIELD WIRING DIAGRAM

Select a location for room thermostat that is away from supply air registers, on draftfree interior wall, and not near lights, television, direct sunlight, or other heat sources.

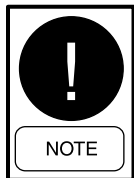

Thermostats with heat anticipators should have the heat anticipator set for 0.20 AMPS on 5 kW units; 0.40 AMPS on 7.5-15 kW units.

17. SEQUENCE OF OPERATION ON HEATING CYCLE

1. Room thermostat calls for heat, connecting R to W terminals.
2. Electric Heat sequencer relay (1S) is energized.
3. On 2.5 & 5KW models the electrical heater is energized between 1-24 seconds after time delay is energized. Heating fan is energized simultaneously with heating element operation.

4. On a furnace with two heating elements (7.5 kW or 10 kW), the 2nd element will be energized approximately 90 seconds after the first stage is energized. A three element furnace (15 kW) will energize the 3rd element approximately 90 seconds after the second stage.
5. When the room thermostat is satisfied, terminals R & W on the thermostat open, de-energizing the 1S sequencer relay.
6. The bank of heating elements will be disconnected in descending order.

SEQUENCE OF OPERATION ON COOLING CYCLE

1. Room thermostat calls for cooling connecting R to Y terminals.
2. The compressor and condenser fan start immediately on a call for cooling. Air circulating fan also starts immediately with cooling operation.
3. When the room thermostat is satisfied, terminal Y on the module is de-energized.
4. The compressor and condenser fan stop immediately when the thermostat is satisfied.
5. The air circulating fan continues to run for an off delay period of 100 seconds. The off delay on the cooling cycle is factory set for maximum efficiency. Adjustment of this delay is not recommended.

18. FURNACE SECTION START-UP CHECKLIST

Before starting furnace for the first time, be sure you can answer "Yes" to each of these questions:

1. Is the furnace level?
2. Have you cleared away all loose construction and insulation materials?
3. Is furnace installed within proper clearances to combustible materials? See Section 7.
4. Does electrical wiring follow current National Electrical Code ANSI 70 or CSA C22.1 as well as local codes? See Section 19.
5. Is furnace electrically grounded? See Section 19.
6. Is room thermostat properly installed? See Section 19.
7. Is duct work system correctly sized and sealed? See Section 13.
8. Are air filters in place and correctly sized? See Section 15.

19. SYSTEM BALANCE



Electric heating elements require a minimum airflow to ensure proper heating output and maximum element operating life. Low airflow will also cause poor cooling performance.

Blower speed taps are factory set for optimum heating and cooling airflow ranges.

Refer to Table 3 for factory blower speed settings, and minimum allowable heating airflow.

Heating speed tap should not normally be reduced below initial factory setting. Some duct system configurations and supply register locations may result in "cold blow".

TABLE 3 - BLOWER SETTINGS

UNIT MODEL	FACTORY BLOWER SPEED SETTINGS		RECOMMENDED MIN. HEATING CFM
	COOLING	HEATING	
SEAC251212	Med-Hi	Low	150
SEAC051212	Med-Hi	Med-Lo	300
SEAC751212	Medium	High	450
R/SEAC051812	Medium	Low	300
R/SEAC751812	Medium	High	450
R/SEAC101812	High	Low	575
R/SEAC052412	High	Low	300
R/SEAC752412	High	Medium	450
R/SEAC102412	Low	Low	575
R/SEAC152412	Low	High	825
R/SEAC753012	High	Low	450
R/SEAC103012	High	Low	575
R/SEAC153012	High	High	825



Operating furnace below the minimum heating airflow may cause poor heating performance and decreased resistant heater life.

Installed system must be test run to ensure operation with sufficient heating and cooling airflow. Total system static pressure should be measured and compared with airflow performance data shown in Table 1.

Measuring duct work static pressure

1. Place slope gauge near furnace where level, and adjust scale to read 0.00 inches W.C
2. Insert one static pressure tap into the supply air plenum. Insert other static pressure tap in return air duct on the air entering side of the filter.
3. Connect pressure tap attached to supply air duct or warm air supply plenum

4. Connect pressure tap attached to return air duct to negative pressure side of slope gauge.
5. Start blower
 - a. Heating speed blower can be run by jumping terminals "R" and "G" on 24 volt terminal block located on the Control Module.
 - b. Cooling speed blower can be run by jumping terminals "R" and "Y" on 24 volt terminal block located on the Control Module.
6. With blower running, read duct work static pressure from slope gauge.
7. Duct work static pressure should not exceed 0.3 inches W.C. in order to ensure proper volume of air flow.
8. Remove jumper wire from 24 volt terminal strip. Remove pressure taps and seal holes in duct work. Failure to seal holes could result in reduced system performance.

Dirty or clogged evaporator coils cause low suction pressures and lost cooling capacity.

With a clean condenser coil, the air temperature leaving the condenser fan discharge should be approximately 33oF above the outdoor air temperature. The saturated condensing temperature should be approximately 38oF above the outdoor air temperature.

If the condensing pressure is higher than shown in the table below, dirt in the condenser must be suspected.

To clean the condenser coil, remove the wall grille from the outside and remove the accumulated dirt from the air intake face of the coil using a brush and/or vacuum cleaner. Always remove all dislodged dirt from inside the wall sleeve so that it will not be sucked back into the condenser coil.

20. MAINTAINING UNIT IN GOOD WORKING ORDER



Follow these procedures before inspecting furnace.

- Turn room thermostat to its lowest or off setting.
- Wait at least five minutes for furnace to cool if it was recently operating.
- Turn off furnace electrical power; failure to do so could result in injury or death.



Use only recommended replacements parts. Failure to do so could improper furnace operation, resulting in damage, injury or death.

Perform periodic preventive maintenance once before heating season begins and once before cooling season. Inspect, clean and repair as needed the following items:

1. All electrical wiring and connections, including electrical ground.
2. All supply air and return air ducts for obstructions, air leaks and loose insulation.
3. Blower housings, motors and wheels, and air filters. Blower motors do not require oiling.
4. Inspect evaporator and condenser coils for accumulations of dirt and debris, and clean as required. If the coils appear dirty, clean them using mild detergent or a commercial coil cleaning agent.

Outdoor Temp °F	Condensing Pressure (psig)
70	220
75	235
80	255
85	270
90	290
95	310

Unit Cooling Capacity (BTU/HR.)

SEAC**1212
 SEAC**1812
 SEAC**2412
 SEAC**3012

REAC**1812
 REAC**2412

R-22 Refrigerant Charge

2 lb.-14 oz.
 3 lb.-14 oz.
 4 lb.- 8 oz.
 4 lb.-14 oz.

SKYPAK ELECTRIC/ELECTRIC

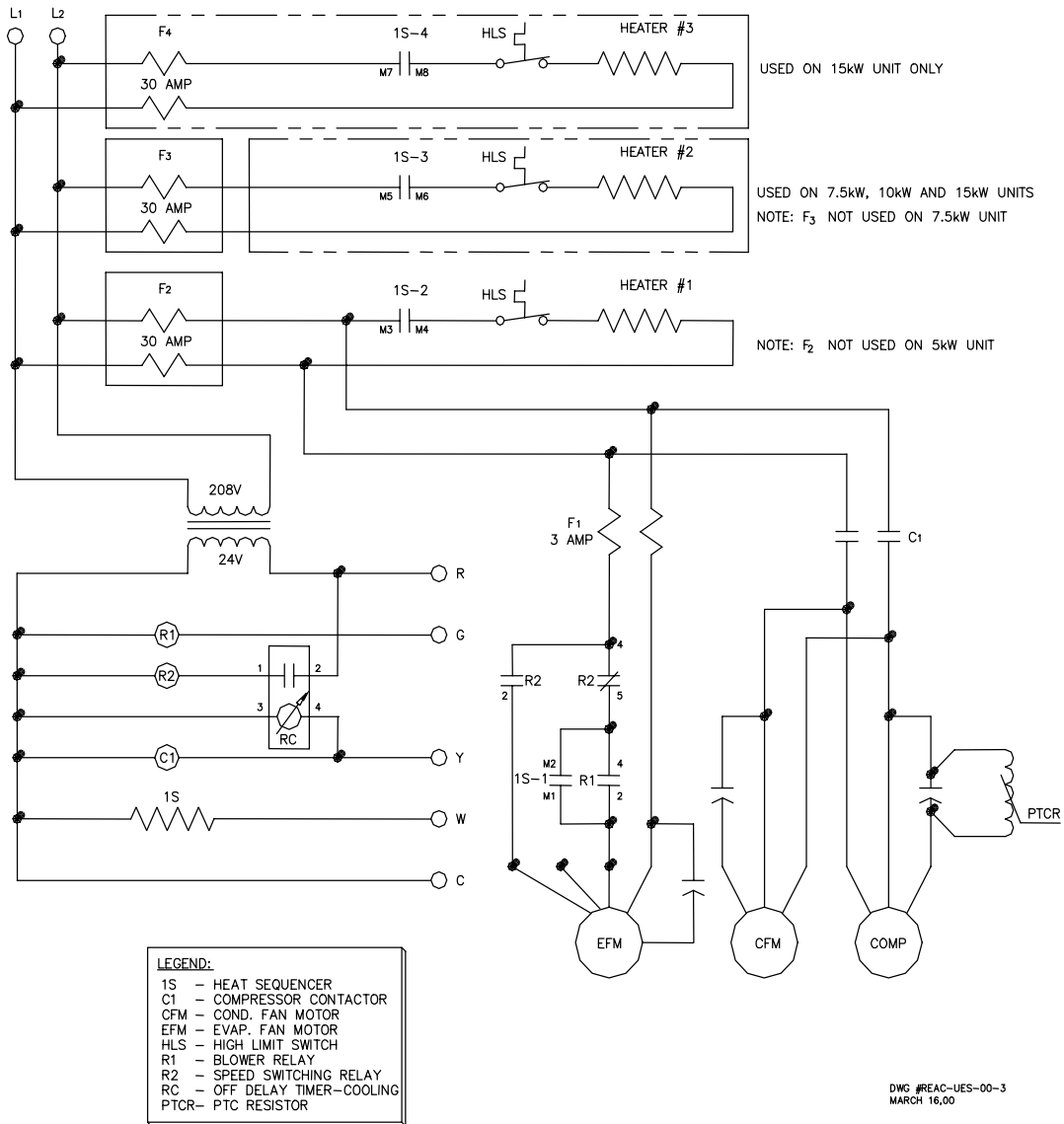

NOTES

NOTES

LIMITED WARRANTY

Johnson Controls warrants this product to be free from defects in workmanship or material for a period of one year from date of original installation or 18 months from date of shipment, whichever comes first

Johnson Controls obligation under this Warranty is LIMITED to repairing or replacing at our sole option, at our factory, any part thereof which shall be returned to our factory, transportation charges prepaid and which on examination proves to have been thus defective under normal domestic use not exceeding the fuel rating. The defective part should be returned through a qualified servicing dealer. Upon warranty determination, the replacement part will be shipped freight collect and assumes the unexpired portion of this Limited Warranty.

When a defective part can be repaired or replaced, Johnson Controls shall not be obligated to repair the entire unit or any part thereof other than the defective part.

This warranty applies only to the original homeowner, and is subject to the terms and conditions hereof.

COMPRESSOR – FIVE YEAR LIMITED WARRANTY

In addition to the One Year Limited Warranty, Johnson Controls warrants the compressor to be free from defects in workmanship or material for a period of five (5) years from the date of original installation. If a compressor fails during this five year period, a new compressor will be supplied. The customer will be responsible for freight costs from our factory for delivery of the replacement compressor and also for the return of the defective compressor which may be required under the terms of the Warranty. Labor and any other expense involved in replacing the compressor is not covered by this Warranty.

LABOR AND COST NOT COVERED

This Warranty provides only replacement parts or credits, and does not provide for or cover any labor, shipping, handling or other costs for service travel, servicing, removing, or installing any parts.

EXCLUSIONS

This Warranty shall be void if:

1. The unit is not installed by a licensed or otherwise qualified or contractor and in compliance with the Installation Manual, applicable installation and good trade practices.
2. The defect or damage is caused by accident, abuse, negligence of any person or company, misuse, riot, flood, fire or Acts of God.
3. The unit is not operated and regularly serviced and maintained as called for in the Users' Manual.
4. Damages are caused by operating the unit in a commercial or corrosive atmosphere containing any damaging or dangerous chemicals.
5. The unit is modified or services in a manner not in accordance with the Installation Manual and Users' Manual.
6. Components, replacement parts, or other accessories not compatible with the unit or not approved by Johnson Controls have been used with or attached to the unit.
7. The defect or damage is not caused by Johnson Controls, or it arises from circumstances beyond the control of Johnson Controls.
8. The unit is installed outside the United States or Canada, or has been removed from the place where it was originally installed.

THIS WARRANTY IS IN LIEU OF ALL OTHER WARRANTIES, OBLIGATIONS OR LIABILITIES, EXPRESSED OR IMPLIED BY EMPLOYEES OR REPRESENTATIVES OF JOHNSON CONTROLS. ALL STATUTORY, EXPRESSED OR IMPLIED WARRANTIES, INCLUDING THE IMPLIED WARRANTY OF MERCHANTABILITY AND FITNESS FOR A PARTICULAR PURPOSE ARE HEREBY NEGATED AND EXCLUDED. ANY CLAIMS FOR INCIDENTAL AND CONSEQUENTIAL DAMAGES, OR ANY OTHER DAMAGES OR EXPENSES BEYOND THE TERMS OF THIS LIMITED WARRANTY ARE HEREBY EXPRESSLY NEGATED AND EXCLUDED.

